



## Series “FC” Cabinet

### Function

To protect electronic components including controls and instruments.

### Features

Aluminum enclosures for protection from all forms of outdoor natural elements including rain, sleet and snow, also seepage and splash.

### Specifications

#### Enclosure

1. Completely fabricated from .125”-thick type 5052-H32. Vinyl coated, mill-finished aluminum utilizing intermittently welded construction.
2. “C” channels on rear to simplify panel mounting.
3. All internal and external hardware utilize non-corrosive material



#### Door

1. Main door lock – industrial, standard pin tumbler lock with #2 key.
2. Closed-cell neoprene door seal gasket.
3. Heavy gauge aluminum hinge utilizing a non-removable stainless steel hinge pin.

---

# Series “FC” Cabinet

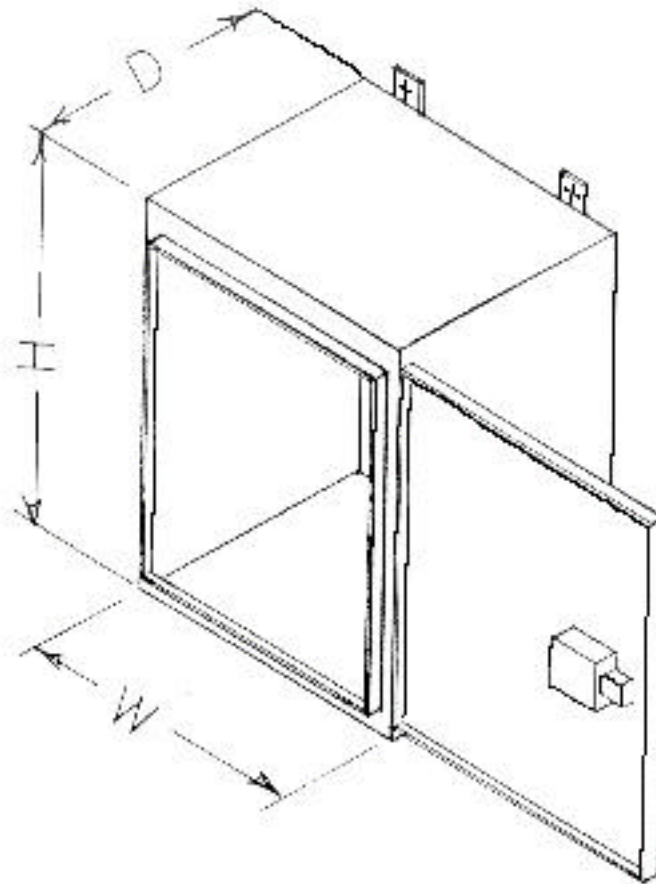

## Options

1. Available with height, width and depth variations in one-inch increments.
2. Optional Shelf
3. Special finish per customer requirements.

MODEL	H x W x D
FC100	14 x 10 x 7
FC101	14 x 11 x 11
FC102	14 x 14 x 7
FC103	16 x 12 x 8
FC104	16 x 14 x 12
FC105	22 x 15 x
FC106	16 x 14 x 10