



Size 4 Cabinet

Function

To protect electronic components including controls and instruments.

Features

Aluminum enclosures for protection from all forms of outdoor natural elements including rain, sleet and snow, also seepage and splash.

Specifications

Enclosure

1. Completely fabricated from .125"-thick type 5052-H32. Vinyl-coated, mill finished aluminum utilizing intermittently welded construction, subsequently weatherproofed with silicone sealant.
2. Internal attaching components include four (4) adjustable "C" mounting channels (2 per side). Add two (2) slotted rails on rear wall for attaching equipment panels.
3. Door opening single-flanged in the sides and bottom, and double-flanged on top to prevent water drops when the door is open. Opening includes a mount for two door-operated switches.
4. Thermoconvection air ventilation system utilized with provisions for mounting fan for forced-air cooling. Exhaust outlet openings provided under the roof overhang.
5. All internal and external hardware utilize non-corrosive material.
6. Adjustable 3/8"-diameter stainless steel door stop can be latched in various positions.
7. Two (2) shelves included



Door

1. Provided with three-point locking mechanism with duplex nylon rollers top and bottom.
2. 3/4"-diameter stainless steel outward turning handle with provisions for padlocking.
3. Main door lock – industrial standard pin tumbler lock with #2 key.
4. Louvered inlet with filter to prevent dirt from entering with air flow.
5. Closed-cell neoprene door seal gasket.
6. Heavy gauge aluminum butt hinge utilizing a non-removable 3/16"-diameter stainless steel hinge. Carriage bolted in place for ease of door removal.
7. 2"-deep, fabricated switch compartment included with standard "police" lock and 14-gauge stainless steel continuous hinge with 3/32"-diameter hinge pin riveted in place. Compartment mounted flush to the door.

Size 4 Cabinet

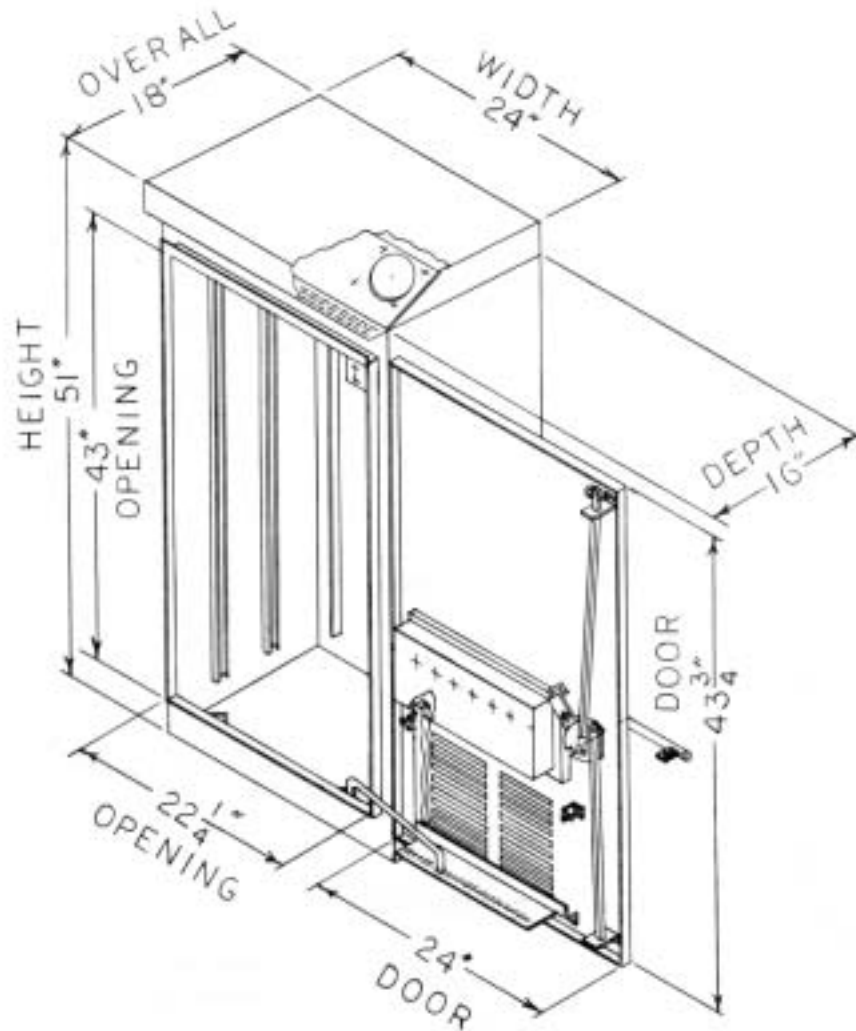

Options

1. Inward-rotating door handle to eliminate door handle projection.
2. Double-flanged door frame to provide a better splash shield.
3. Continuously welded enclosure for maximum protection from contaminants.
4. Heavy gauge stainless steel continuous hinge utilizing a non-removable 3/16"-diameter hinge pin.
5. Pedestal or pole mount available
6. Special lock keying combinations.
7. Special finish per customer requirements.

CATALOG NO.	DESCRIPTION
EL 762*	Pedestal Mount
EL 763**	Pole Mount

* Order 1 EL712 Collar, if required

**Order 2 pole mount brackets, UL26, if required