



Size M Cabinet

Function

To protect electronic components including controls and instruments.

Features

Aluminum enclosures for protection from all forms of outdoor natural elements including rain, sleet and snow, also seepage and splash.

Specifications

Enclosure

1. Completely fabricated from .125"-thick type 5052-H32. Vinyl-coated, mill-finished aluminum utilizing intermittently welded construction, subsequently weatherproofed with silicone sealant.
2. Internal attaching components include (4) adjustable "C" mounting channels (2 per side), and (2) slotted rails on rear wall for attaching equipment panels.
3. Door opening is single-flanged on the sides and bottom, and double-flanged on top to prevent water drops when the door is open. Opening includes a mount for two door-operated switches.
4. Thermoconvection air ventilation system utilized with provisions for mounting fan for forced-air cooling. Exhaust outlet openings provided under roof over-hang.
5. All hardware utilizes non-corrosive material.
6. Adjustable 3/8"-diameter stainless steel door stop can be latched in various positions.

Door

1. Provided with three-point locking mechanism.
2. 3/4"-diameter stainless steel inward turning handle with provisions for padlocking.
3. Main Door lock – industrial standard pin tumbler lock with #2 key.
4. Louvered inlet with filter to prevent dirt from entering with air flow.
5. Closed-cell neoprene door seal gasket.
6. Heavy gauge aluminum butt hinge utilizing a non-removable 3/16"-diameter stainless steel hinge. Carriage bolted in place for ease of door removal.
7. 2"-deep, fabricated switch compartment include with standard "police" lock and 14-gauge stainless steel continuous hinge with 3/32"-diameter hinge pin riveted in place. Compartment mounted flush to the door.



Size M Cabinet

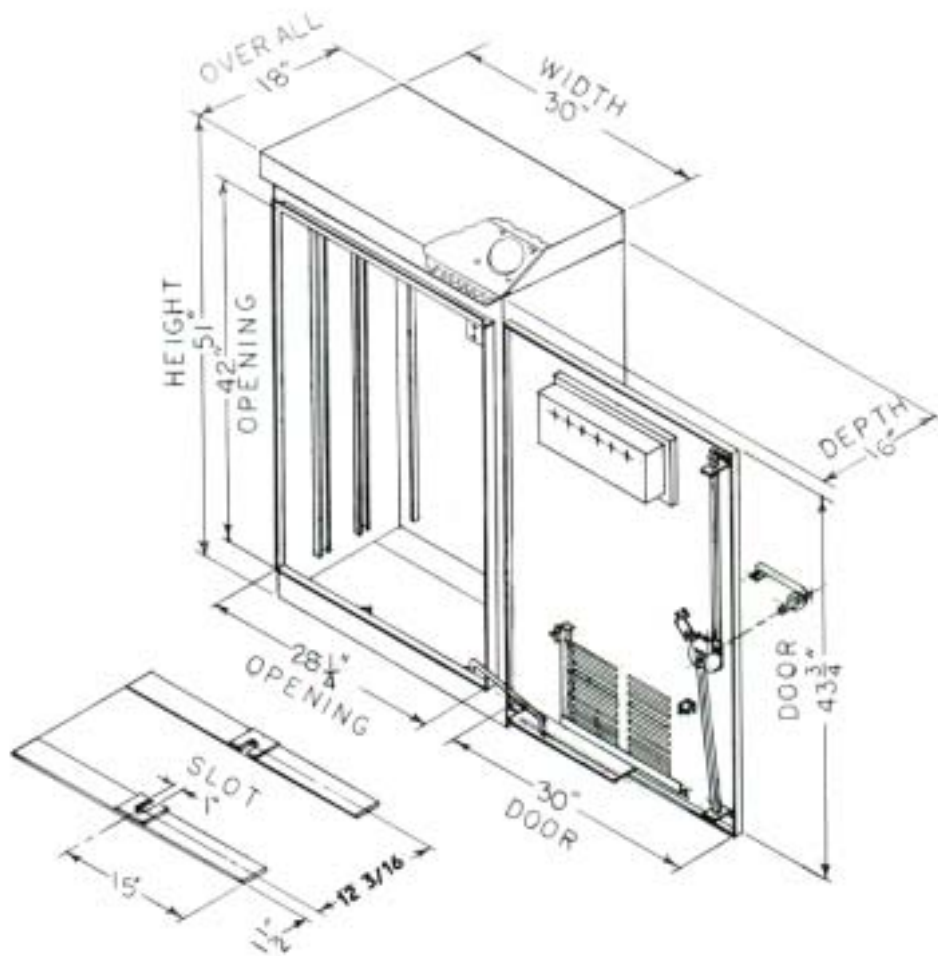

Options

1. Special fan mounting available.
2. Outward rotating door handle.
3. Double-flange door frame to provide a better splash shield.
4. Continuously welded enclosure for maximum protection from contaminants.
5. Heavy gauge stainless steel continuous hinge utilizing a non-removable 3/16"-diameter hinge pin.
6. Base or pole mount available.
7. Special lock keying combinations.
8. Door locking mechanism utilizing duplex nylon rollers, top and bottom.
9. Three position automatic door stop positioning mechanism.
10. Special finish per customer requirements.

CATALOG NO.	DESCRIPTION
EL 702*	Base Mount
EL 702-S1**	Pole Mount

* Order 1 (set of 2) anchor bolts, UA243, if required

**Order 2 pole mount brackets, UL26, if required