

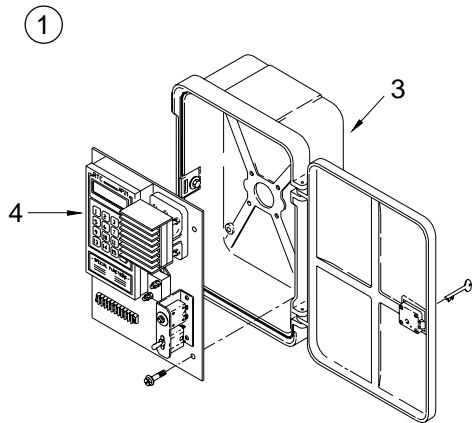

ITEM	DESCRIPTION	PART NO.
<b>FLASHER CONTROLLER ASSY:</b>		
①	w/ 5-Pin Flasher .....	SE-1000
②	w/ Nema Flasher .....	SE-1004
③	<b>FLASHER CABINET ASSY, w/ Police Type I Lock .....</b>	<b>SE-1002</b>
<b>BACK PANEL ASSY:</b>		
4	w/ 5-Pin Flasher, Time Clock, Lightning Arrestor, Circuit Breaker, & Toggle Switch .....	SE-1007
5	w/ Nema Flasher, Time Clock, Lightning Arrestor, Circuit Breaker, & Toggle Switch .....	SE-1006



**Notes:**

1. All assemblies are supplied standard with stainless steel fasteners.
2. Please specify options when ordering.

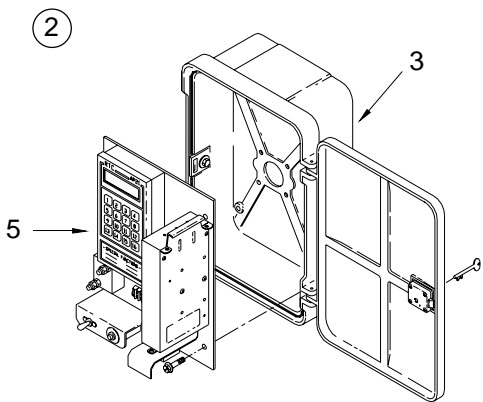

ITEM 1-2 OPTIONS
TOP/BOTTOM MOUNT
PAINT

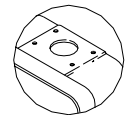
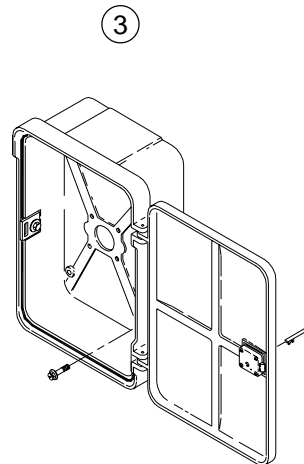

Top/Bottom Mount  
Option

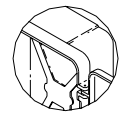

No Mount  
Option

OPTIONS
TOP/BOTTOM MOUNT
NO MOUNT
PAINT