



# LED Traffic Signal Module Incandescent Look IL Series

**GREEN** Technology

## The Leotek LED Advantage

A conventional incandescent look with "Fail-State Impedance" design to ensure controller and monitor compatibility in the event of loss of light output.

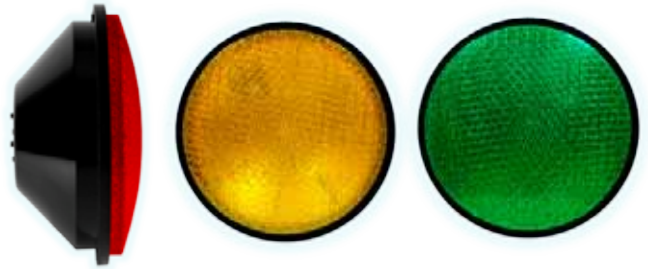

## Features and Benefits

- Environmentally friendly
- Significant energy and maintenance savings
- Intertek ETL verified
- 8" and 12" modules
- Tinted or clear lens options
- Multiple connections available for specific applications
- Exceptional color uniformity and readability
- Excellent moisture and dust resistance through complete O-ring sealing
- Robust hard-coated and UV-stabilized polycarbonate lens for increased longevity against the elements
- Engineered aluminum heat sink for optimum thermal management
- Built-in Constant Current Source (CCS) provides uniform light output from the first to the last modules
- Maintains 70% of the initial lumen intensity after 50,000 hours of operation
- 5-Year Limited Warranty

## Technical Data

Operating Temperature: : -40°F to 165°F (-40°C to 74°C)	Turn-On/Turn-Off Time: : <75msec
Operating Voltage: : 80 -135Vac, 10.5-28Vdc	Turn-Off Voltage: : 35Vac
Power Factor: : >0.90	Total Harmonic Distortion (THD): : <20%



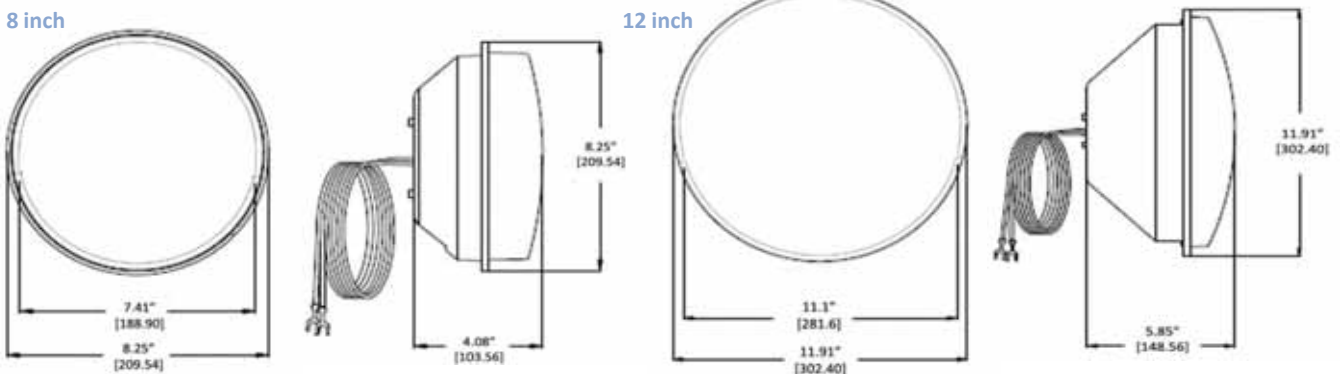















## Mechanical Dimensions [mm(in)]



# Model Specifications and Ordering Options

Example: TSL-12R-LX-IL3-A1

TSL-(SIZE)(COLOR)-LX-(IL TYPE)-(VOLTAGE)

Model Number and Color	IL Type	Wattage Drawn	Voltage	Dominant Wavelength	Maintained Intensity (cd) Min.	Standard
<b>8 inch</b>						
TSL-08R-LX-IL3-A1 <sup>3</sup> 	3	8	80-135Vac	626	165	ITE 2005/ETL <sup>2</sup>
TSL-08Y-LX-IL3-A1 <sup>3</sup> 	3	13	80-135Vac	589	410	ITE 2005/ETL <sup>2</sup>
TSL-08G-LX-IL3-A1 <sup>3</sup> 	3	9	80-135Vac	500	215	ITE 2005/ETL <sup>2</sup>
TSL-08R-LX-IL1-A1 	1	5	80-135Vac	626	133	ITE 1998/Caltrans
TSL-08Y-LX-IL1-A1 	1	10	80-135Vac	589	267	ITE 1998/Caltrans
TSL-08G-LX-IL1-A1 	1	9	80-135Vac	500	267	ITE 1998/Caltrans
TSL-08R-LX-IL1-B1 	1	5	10.5-28Vdc	626	133	N/A
TSL-08Y-LX-IL1-B1 	1	11	10.5-28Vdc	589	267	N/A
TSL-08G-LX-IL1-B1 	1	9	10.5-28Vdc	500	267	N/A
<b>12 inch</b>						
TSL-12R-LX-IL3-A1 <sup>3</sup> 	3	11	80-135Vac	626	365	ITE 2005/ETL <sup>2</sup>
TSL-12Y-LX-IL3-A1 	3	13	80-135Vac	589	910	ITE 2005
TSL-12Y-LX-IL3-A1-C (High Temp <sup>1</sup> ) <sup>3</sup> 	3	17	80-135Vac	589	910	ITE 2005/ETL <sup>2</sup>
TSL-12G-LX-IL3-A1 <sup>3</sup> 	3	10	80-135Vac	500	475	ITE 2005/ETL <sup>2</sup>
TSL-12R-LX-IL1-A1 	1	8	80-135Vac	626	399	ITE 1998/Caltrans
TSL-12Y-LX-IL1-A1 	1	14	80-135Vac	589	678	ITE 1998/Caltrans
TSL-12G-LX-IL1-A1 	1	12	80-135Vac	500	678	ITE 1998/Caltrans
TSL-12R-LX-IL1-B1 	1	9	10.5-28Vdc	626	399	N/A
TSL-12Y-LX-IL1-B1 	1	9	10.5-28Vdc	589	678	N/A
TSL-12G-LX-IL1-B1 	1	8	10.5-28Vdc	500	678	N/A

**Options:** Tinted lens standard, clear lens optional.

<sup>3</sup> When ordering clear lens: On IL3 ETL Verified models, please add “-CLR” to model number. For IL1 models, please indicate “clear lens.”

<sup>1</sup>Meets ITE 2005 Temperature at +165°F (+74°C).

<sup>2</sup>Intertek ETL Verified (tinted and clear lens)

## Standard Conformance



- FCC Compliant for Electrical Noise
- MIL-STD-810F Moisture Resistant
- MIL-STD-883 Mechanical Vibration
- NEMA TS2 Transient Voltage Protection over 2000V

### ITE VTCSH Compliance - LED Circular Signal Supplement – June 2005

- |                        |             |                       |               |
|------------------------|-------------|-----------------------|---------------|
| • Conditioning         | ITE 6.4.2   | • Luminous Intensity  | ITE 6.4.4.1-4 |
| • Mechanical Vibration | ITE 6.4.3.1 | • Chromaticity        | ITE 6.4.4.6   |
| • Temperature Cycling  | ITE 6.4.3.2 | • Current Consumption | ITE 6.4.6.1   |

**LEOTEK USA**  
1330 Memorex Drive  
Santa Clara, CA 95050  
Toll Free: (888) 806-1188  
Fax: (408) 980-0538

**LEOTEK TAIWAN**  
No. 50 Lung-Yuan 7<sup>th</sup> Road  
Lung-Tan, Tao-Yuan Hsien 325  
Taiwan  
Telephone: 866-3-4995939  
Fax: 866-3-4995930

[www.leotek.com](http://www.leotek.com)  
[www.liteon.com](http://www.liteon.com)

